

PRODUCT SPECIFICATIONS

ITEM NUMBER	MODEL DESCRIPTION	MAX. PRESSURE		VOLTAGE	FREQUENCY	HP	kW	NET WT.		AMPS	TANK SIZE
		PSI	BAR					lbs.	kg		
1068760	106R-25B	116	8	230 VAC	50/60Hz	.75	.56	76	34	3.2/3.6	25L

NOTES:

1. TECHNICAL DATA SUBJECT TO CHANGE WITHOUT NOTICE
2. ALL DIMENSIONS ARE FOR REFERENCE ONLY.

AMBIENT: 5/40 °C

RELATIVE HUMIDITY: 20-80% NON CONDENSING

ENVIRONMENT: CLEAN DUST FREE

REGULATORY: CERTIFICATION PENDING

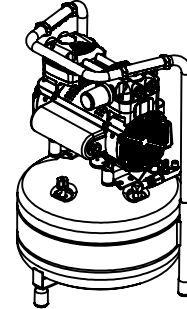

PRODUCT PERFORMANCE:

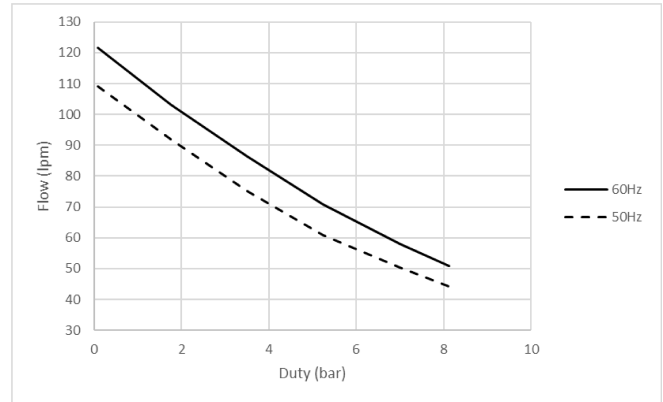
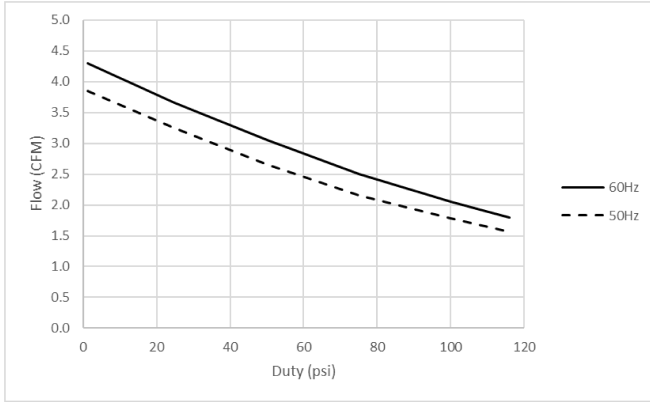

PRODUCT DIMENSIONS:

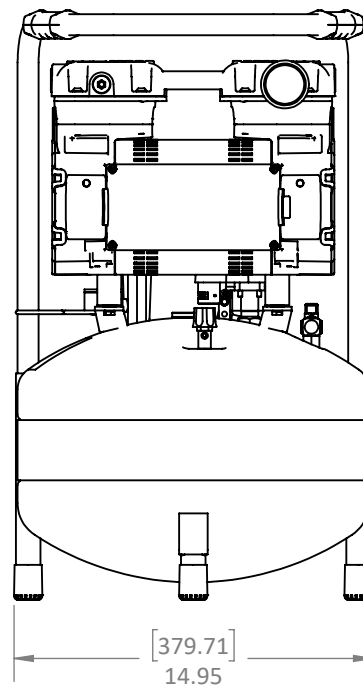
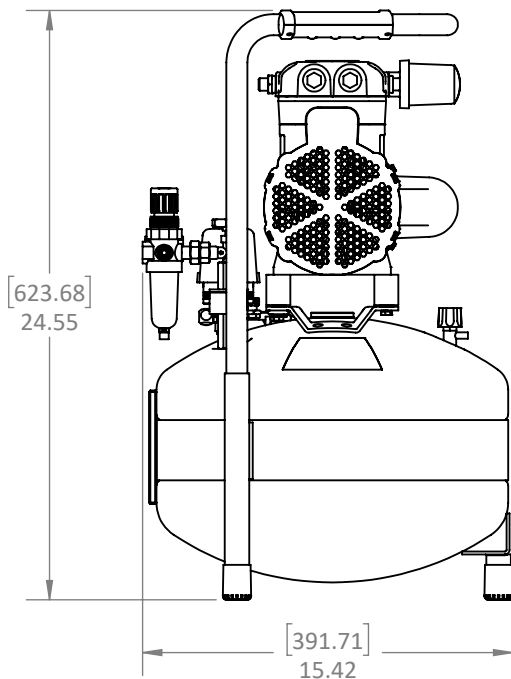



WolfLabs

Pricing on any accessories shown can be found by keying the part number into the search box on our website.

The specifications listed in this brochure are subject to change by the manufacturer and therefore cannot be guaranteed to be correct. If there are aspects of the specification that must be guaranteed, please provide these to our sales team so that details can be confirmed.

www.wolflabs.co.uk

Tel : 01759 301142

Fax : 01759 301143

sales@wolflabs.co.uk

Please contact us if this literature doesn't answer all your questions.